

# New Design and Simulation of 28GHz Microstrip Patch Antenna for 5G Applications

Zainab S.Jameel<sup>1\*</sup>, Huda A.Abbood<sup>2</sup>, Dunya Sh. Wais<sup>3</sup>

<sup>1,2,3</sup> Faculty of Engineering, Mustansiriyah University, Baghdad, Iraq

\*Email: [Zainab.saadoon@uomustansiriyah.edu.iq](mailto:Zainab.saadoon@uomustansiriyah.edu.iq)

\*Email: [hudaabdulameer@uomustansiriyah.edu.iq](mailto:hudaabdulameer@uomustansiriyah.edu.iq)

**Abstract**— In this article, a design and simulation of microstrip patch antenna operating at 28 GHz resonance frequency is proposed. A rectangular patch is used in the suggested antenna with three slots embedded fed using a microstrip line. The antenna dimensions are 12 ×10×0.508 mm with Rogers RT/Duroid5880 substrate of  $\epsilon_r = 2.2$  and thickness = 0.508 mm. The results of the simulation are computed using CST software. Simulation results show the reflection coefficient and gain are -39.534 dB and 6.19 dBi respectively.

**Index Terms**— Microstrip patch Antenna; Rogers RT/Duroid5880; 5G Antenna; CST Software; 28GHz

## I. INTRODUCTION

The technologies of wireless communication have evolved very rapidly to apply to the necessity of high movement volume in electronic appliances. 5G technologies utilize greater frequency bands to deliver data with big capabilities supporting rates of multi-Gbps data, in addition to collecting unlimited broadcast of data in latest mobile technology [1]. The International Telecommunication Union (ITU) has designated a frequency range for the 5G system that lies in the millimeter-wave radio band and spans from 24GHz to 80GHz.[2]

5G currently is considered to be one of the most innovative technology of wireless communication. This technology plans to progress wireless networks performance by heightening the speeds of transmission, improving the responsiveness of the network, and coverage boarding. Additionally, 5G technology is acknowledged for the support of multiple connected devices, comprising self-driving cars, smart devices, medical devices, and others [3]. One of the tools used in 5G technologies is Microstrip patch antenna. It is well-developed and utilized in the equipment of modern telecommunications, which is due to multiple approaches and practices in the designing of antennas and applications [4,5]. There are a number of advantages of microstrip patch antennas such as uncomplicated structure, small dimensions, inexpensive, easy to fabricate, and widely favored in a lot of applications such as operating in dual frequencies, circular polarizations, frequency swiftness, dual

characteristics, wide bandwidth, flexibility of feed line and beam scan which these antennas can easily achieve as expressed in [6,7,8].

The performance of microstrip patch antennas can be improved by a variety of methods, including fractal geometry, defective ground structures, and patch slot cutting [9,10].

Microstrip patch antenna consists of a thin metallic patch and ground plane made of copper or gold material. The patch and ground plane are separated by a dielectric substrate [11,12].

The substrate material used in this antenna design is the Roger RT/Duroid 5880 substrate, with a dielectric constant of 2.2, because it has reinforced PTFE (ceramic or glass) material, which provides low dielectric loss and is suitable for high frequency and broadband applications. Moreover, a substrate with less dielectric delivers improved bandwidth and high efficiency [13].

A microstrip patch antenna has been proposed and constructed as a form of antenna for 5G usage in numerous papers.

Waleed et al. [14] designed a dual band PIFA antenna with the widest bandwidth in both bands (28 GHz and 38 GHz), for 5G applications. A redesigned U-shaped slot in the patch and a shorted patch constitute the proposed antenna At 28 GHz and 38 GHz, respectively, the antenna exhibited a gain of 3.75 dBi and 5.06 dBi, along with a clean radiation pattern and bandwidth of 3.34 GHz and 1.395 GHz.

Omar et al. [15] suggested a design of Roger RT Duroid 5880 based substrate. This antenna used 28GHz as its resonant frequency and gave a return loss of -13.48 dB, and a gain of 6.63 dB. M Darsono et al. [16] introduced a microstrip antenna for fifth generation and utilized Taconic TLY-5 type material substrate in the design. Simulation results showed a gain of 6.72dB and a return loss of -27.7. Prachi et al. [17] introduced a fifth generation small patch antenna that operates in the 28 GHz Ka-band frequency. It was constructed on a Rogers Rt/Duroid 5880 substrate with a 0.254 mm thickness, the antenna had a gain of roughly 5.2 dB and a reflection coefficient of less than -10 dB. Rafal et al. [18] designed a broadband microstrip antenna that resonates at 28 GHz. In this design, a Rogers RT5880 substrate with a dielectric constant of 2.2 was utilized. Results of the research were a gain of 3.6 dBi, and a

return loss of -22.51 dB.

This work proposes a microstrip patch antenna with new design aimed for applications of 5G communication systems with resonance frequency of 28 GHz and geometry of a small size having dimensions of 12 mm × 10 mm × 0.508 m.

## II. ANTENNA DESIGN

The geometry of the suggested antenna is illustrated in Fig.1. The rectangular patch is printed on a substrate of Rogers RT/Duroid5880 with thickness  $h=0.508$  mm and relative dielectric, constant = 2.2. The patch size is  $6.6 \times 5$  mm fed by a microstrip line. Rectangular slots are planted in the center of the patch and on the bottom edges. The ground size is  $12 \times 10$  mm. The proposed antenna gives minimum return loss at 28GHz which is suitable for 5G applications. Fig.1 (a) and (b) show the patch layer and ground layer of the suggested antenna respectively. Fig.2 shows the suggested antenna's 3D, view.

The geometrical parameters of proposed antenna are selected by running various parameter sweeps and finally the best possible parameters for proposed configuration are obtained as shown in Table 1.

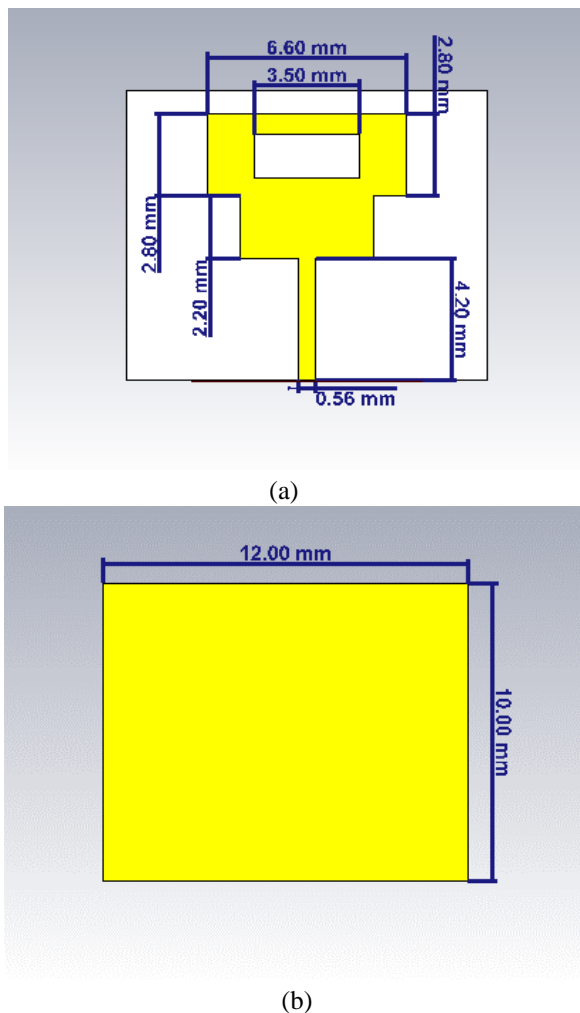

Fig. 1. The Suggested Antenna (a) Patch layer (b) Ground layer

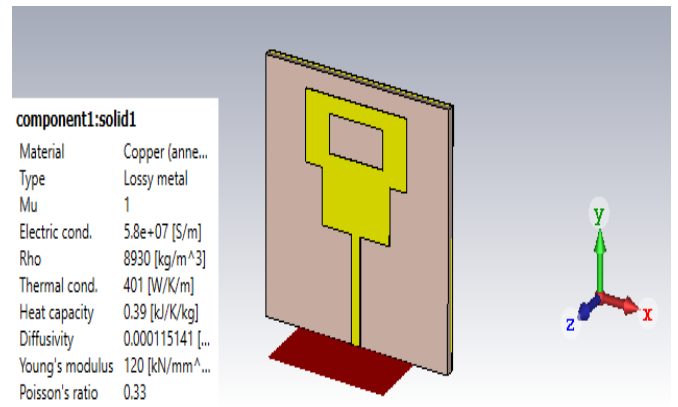

Fig. 2. 3D View of the Suggested Microstrip Patch Antenna

The dimensions of microstrip patch antenna are created with the following formula of approximation [10,19].

### 1-Patch Width W

$$W = \frac{c}{2f_r \sqrt{\frac{\epsilon_r + 1}{2}}} \quad 1$$

Where  $c$  is the electromagnetic wave's velocity in free space.  $f_r$  is the operating frequency.  $\epsilon_r$  is the substrate's dielectric constant.

### 2- Patch Length L

$$L = \frac{c}{2f_r \sqrt{\epsilon_{eff}}} - 2\Delta L \quad 2$$

Where  $\epsilon_{eff}$  effective dielectric constant given as follows.

$$\epsilon_{eff} = \frac{\epsilon_r + 1}{w} + \frac{\epsilon_r - 1}{w} \left(1 + \frac{12h}{w}\right)^{-\frac{1}{2}} \quad 3$$

and  $\Delta L$  is the extended incremental length given as follows.

$$\Delta L = 0.412h \frac{(\epsilon_{eff} + 0.3) \left(\frac{w}{h} + 0.264\right)}{(\epsilon_{eff} - 0.258) \left(\frac{w}{h} + 0.8\right)} \quad 4$$

Table.1 shows the parameters of the suggested antenna and their dimension.

TABLE I. PARAMETERS'DIMENSIONS OF SUGGESTED

Parameters	Dimensions (mm)
Length of patch $L_p$	5
Width of patch $W_p$	6.6
Ground plane Length $L_g$	10
Ground Plane width $W_g$	12
Height of substrate, $h_s$	0.508

Width of feedline $W_f$	0.56
Length of feedline $L_f$	4.2
Ground Thickness $h_g$	0.035

### Parametric Analysis

In the parametric analysis, the dimensions of certain parameters are changed, and the effects of these changes are examined with respect to the properties of the reflection coefficient, namely the impedance bandwidth ( $\leq -10$  dB), the operating frequency (fr), and the S11 parameter. The parameter sweep function of the CST simulator is used in this experiment. The antenna performance is affected by the following factors: patch length ( $L_p$ ), patch width ( $W_p$ ), and feed width ( $W_f$ ) examined. As seen in Figures 3,4 and 5, the impact of varying the width, length of the patch, and width of the transmission feed on the return loss is investigated.

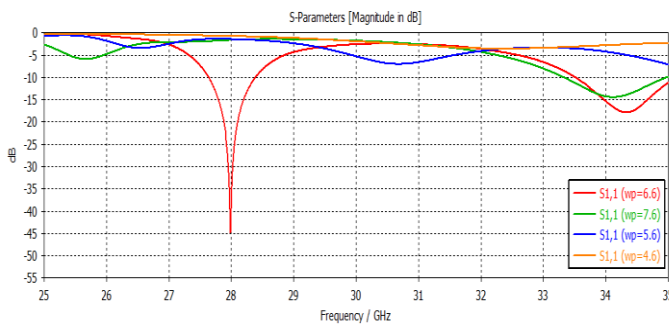

Fig. 3. Effect of changing patch width to the return loss

Figure 3 illustrates how the width of the patch may affect return loss performance.  $W_p = 6.6$  mm, with a return loss of 39.5 dB, is clearly the ideal value for this parameter. Both below and beyond the ideal value, the return loss reduces.

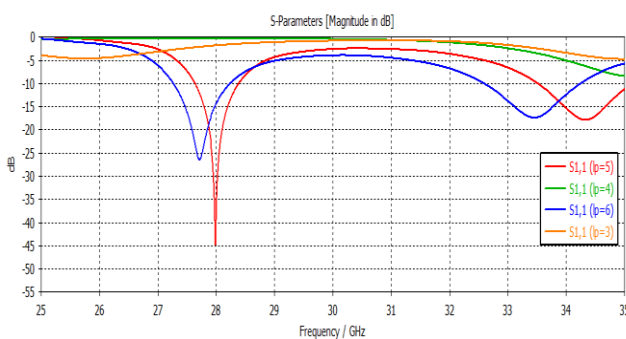

Fig. 4. Effect of changing patch length to the return loss

The proposed antenna's reflection coefficient (S11) as a function of  $L_p$  is shown in Figure 4. It's been found that altering the patch length significantly affects the antenna's reflection coefficient (S11) characteristics, particularly the resonance frequency and return loss value at that frequency.  $L_p$  is expanded in this design from 3 mm to 6 mm in steps of 1 mm. The 28 GHz shifted to the left as the value of  $L_p$  increased. In order to obtain radiation at 28GHz,  $L=5$  mm is selected.

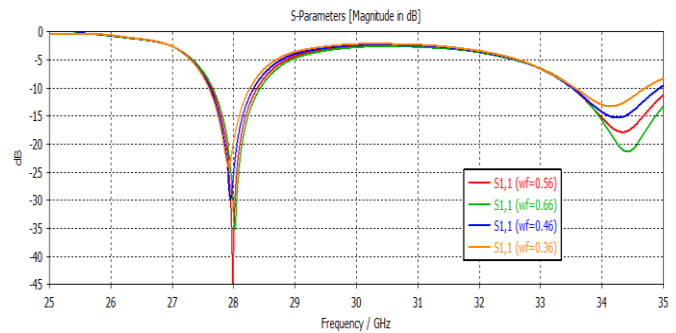

Fig. 5. Effect of changing feeder width to the return loss

Figure 5 shows the impact of feeder width on S11 performance of the antenna. Regarding feeder width, its value influences how well the microstrip feed matches the impedance. The optimal value at which a decent impedance matching is attained at 28 GHz is determined to be  $W_f = 0.56$  mm.

### III. SIMULATED RESULT AND DISCUSSION

The suggested antenna, is created, and simulated with Computer, Simulation Technology (CST) program.

#### A. Reflection Coefficient

The reflection coefficient (return loss) result of the suggested antenna is shown in fig. 6 as achieved by CST simulator which is found to have a value of -39.534 dB resonating at 28 GHz.

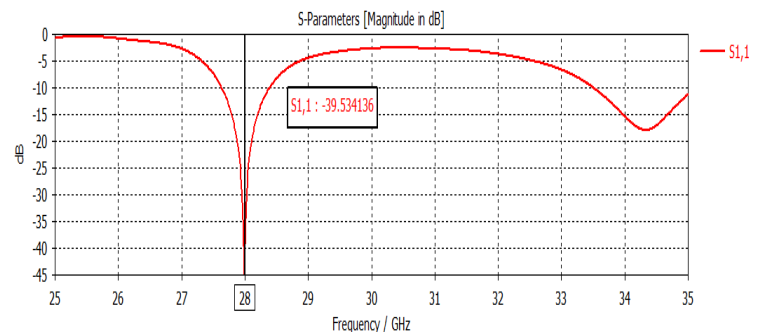
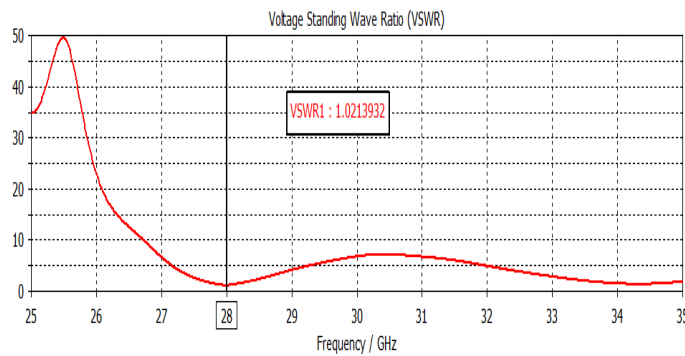

Fig. 6. Return Loss versus Frequency

#### B. VSWR

The other parameter that can be obtained for this antenna is voltage standing wave ratio (VSWR). An ideal VSWR value should be one, a value greater or equal to two should be avoided [19]. Fig. 7 shows that a VSWR value of 1.021 was obtained at 28 GHz operating frequency.



**Fig.7.** VSWR vs. Frequency

**C. Bandwidth**

The rectangular MSPA's bandwidth is found in the regions having a return loss of less than -10 dB [20], which is determined for the proposed antenna between 27.426 GHz and 28.488 GHz. As a result, the proposed MSPA has a bandwidth of 1.062 GHz.

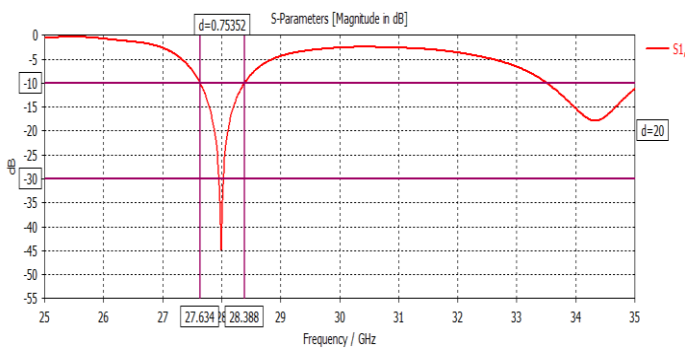

**Fig. 8.** Bandwidth plot of the proposed antenna

**D. Gain**

An antenna's efficiency in transmitting or receiving power in a specific direction is indicated by its gain. The three dimensions far-field of the suggested antenna is plotted in Figure 9 where it is shown the estimated peak gain value is 6.19 dBi at the resonance frequency of 28 GHz.

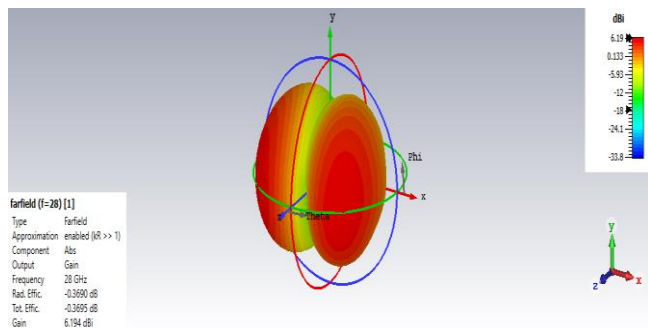

**Fig.9.** 3D plot of far-field gain at 28 GHz

**E. Directivity**

The ratio of the greatest power density to its average value over a sphere as detected in the far field defines the directivity, which quantifies how strongly the antenna radiates power in its chose direction. Figure 10. displays the three-dimensional far-field directivity map of the suggested antenna at the 28 GHz resonance frequency. It is observed that the proposed antenna's peak directivity value is 6.563dBi.

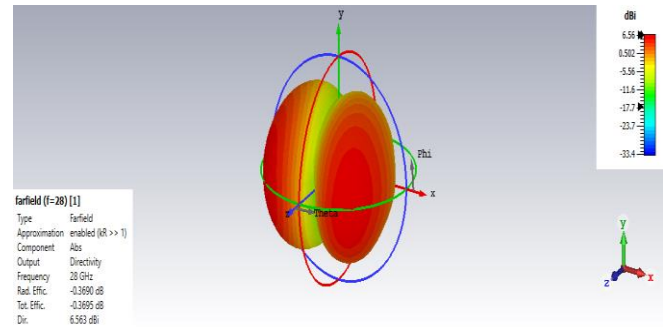

**Fig.10.** 3D plot of far-field directivity at 28GHz

**F. Radiation Pattern**

The distribution of the radiated power from the antenna (for a transmitting antenna) or received via the antenna (for a receiving antenna) as a function of the direction angles from the antenna is known as the radiation pattern. It is typically computed in the far-field region, where it accounts for the E-field and H-field patterns.

**1) E-field pattern**

Figure 11 displays the polar plot of the proposed antenna's Far-field E-field pattern at 28 GHz. It is observed that the main lobe direction is 38.0 degrees and its magnitude is 20.9 dB(V/m). The proposed antenna's Far-field E-field pattern is plotted in three dimensions in Figure 12, indicating that the maximum radiation intensity (Emax) is 20.93 dB(V/m).

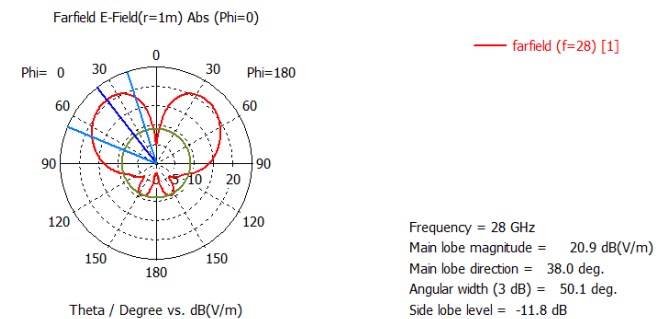

**Fig.11.** Polar plot of Far-field E –field pattern at 28 GHz

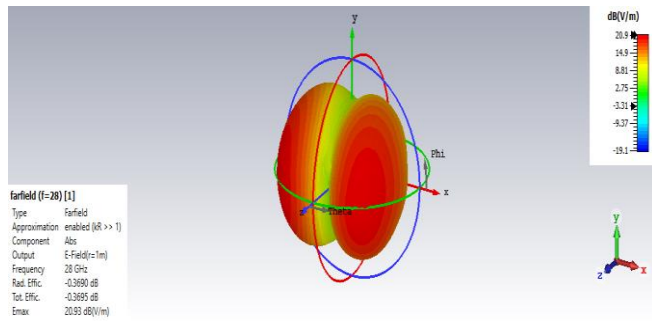

Fig.12. 3D plot of Far-field E –field pattern at 28 GHz

2) H-Field

The polar plot of the proposed antenna's Far-field H-field pattern at 28 GHz is displayed in Figure 13. The major lobe direction is 38.0 degrees, and its magnitude is observed to be -30.6 dB(A/m). Figure 14 displays the three dimensions plot of the planned antenna's Far-field H-field pattern, indicating that the maximum radiation intensity Hmax is -30.59dB(V/m).

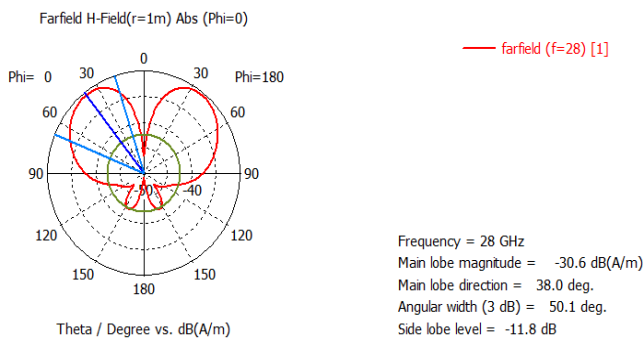

Fig.13. Polar plot of Far-field H –field pattern at 28 GHz

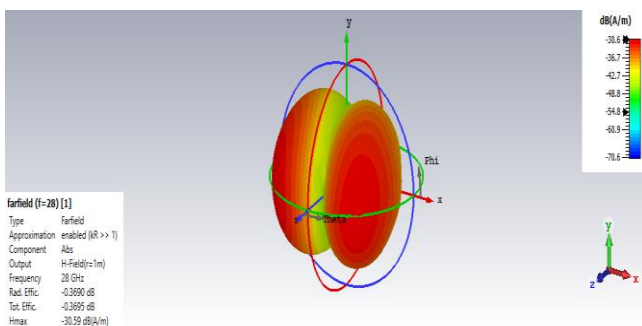

Fig.14. 3D plot of Far-field H –field pattern at 28 GHz

G. Surface Current

Figure 15 shows the dispersion of surface currents at 28 GHz. Along the feed line, there is a concentration of current, and it is noticeable at the slot edges. A maximum current distribution of 516.117 A/m is typically found along the radiating patch.

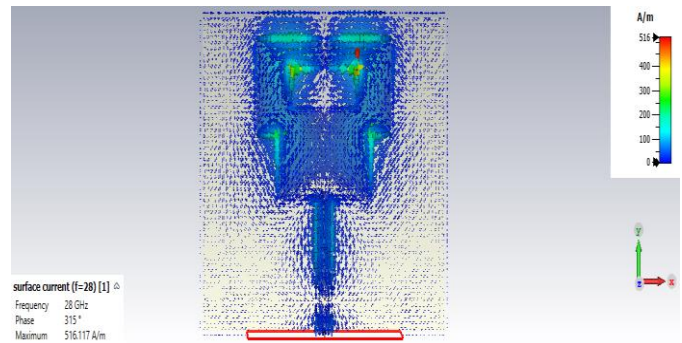

Fig. 15. Distribution of Surface Currents in the Proposed Antenna

TABLE 2. SUMMARY OF SIMULATED RESULTS

Antenna parameters	Values
$S_{11}$	39.534
Bandwidth	753.52 MHz
Gain	6.19 dBi
VSWR	1.02
Efficiency	94.37 %
HPBW	51.0°

IV. The Suggested Antenna as compared with Similar Antennas for 5G System

The performance of the suggested antenna has been compared with other designs in previous research in Table 3. The  $S_{11}$  of the suggested antenna gives minimum return loss with good gain in comparison with the antennas reported in [2, 14, 15, 16, 17, and 18]. Therefore, the suggested antenna gives good compared to other comparable antennas documented in table 3.

TABLE 3. PREVIOUS WORKS COMPARISON

References	Frequency (GHz)	$S_{11}$ (dB)	Gain
This work	28	-39.534	6.194 dBi
[2]	28	-17.68	5.406 dBi
[14]	28/38	Below -10	3.75dB,5.06 dBi
[15]	27.954	-13.48	6.63 dB
[16]	28.06	-27.7	6.72dB
[17]	28	-20.03	5.2 dB
[18]	28	-22.51	3.6dBi

V. CONCLUSION

This paper proposes a new design of microstrip patch antenna aimed for 5G applications with center frequency of 28 GHz using rectangular patch with slot in its middle and two slots on the bottom edges of it. This antenna is constructed on the Rogers RT/Duroid5880 substrate and has overall measurements of 12 x 10 x 0.508 mm. The simulation results show that the values of

the reflection coefficient, gain and VSWR are -39.534dB, 6.19dBi and 1.02 respectively. The above values make the proposed antenna a good option for 5G applications and because of its small size and light weight, the antenna is appropriate for devices which don't have a lot of space.

## REFERENCES

- [1] L. C. Yu and M. R. Kamarudin, 'Investigation of Patch Phase Array Antenna Orientation at 28 GHz for 5G Applications', *Procedia Comput. Sci.*, vol. 86, no. March, pp. 47–50, 2016, doi: [10.1016/j.procs.2016.05.012](https://doi.org/10.1016/j.procs.2016.05.012).
- [2] S. A. Almazok, 'Performance Analysis of mm-Wave Inset-Fed Rectangular Patch Antenna Employing Polyimide Substrate for 5G System mm-Wave Rectangular Patch Antenna Designed for 5G System', vol. 03, no. 02, pp. 1–10, 2022.
- [3] M. A. M. Ali, A. G. S. A. Gaid, M. M. Saeed, and R. A. Saeed, 'Design and Performance Analysis of a 38 GHz Microstrip Patch Antenna with Slits Loading for 5G Millimeter-Wave Communications', *2023 3rd Int. Conf. Emerg. Smart Technol. Appl. eSmarTA 2023*, no. October, pp. 3–9, 2023, doi: [10.1109/eSmarTA59349.2023.10293289](https://doi.org/10.1109/eSmarTA59349.2023.10293289).
- [4] Y. Rahayu, Y. B. Pradana, and Y. Yamada, 'Dual-band frequency reconfigurable 5G microstrip antenna', *Sinergi (Indonesia)*, vol. 27, no. 1, pp. 81–88, 2023, doi: [10.22441/sinergi.2023.1.010](https://doi.org/10.22441/sinergi.2023.1.010).
- [5] M. Tegegn Gameda, K. A. Fante, H. L. Goshu, and A. L. Goshu, 'Design and Analysis of a 28 GHz Microstrip Patch Antenna for 5G Communication Systems', *Int. Res. J. Eng. Technol.*, pp. 881–886, 2021.
- [6] S. K. Hassan and Z. M. Khudair, 'Design and Analysis of a Microstrip Antenna for Superior 5G Communication Performance', *Salud, Cienc. y Tecnol. - Ser. Conf.*, vol. 3, no. June, pp. 0–9, 2024, doi: [10.56294/sctconf2024867](https://doi.org/10.56294/sctconf2024867).
- [7] Y. S. H. Khraisat, 'Design of 4 elements rectangular microstrip patch antenna with high gain for 2.4 GHz applications', *Mod. Appl. Sci.*, vol. 6, no. 1, pp. 68–74, 2012, doi: [10.5539/mas.v6n1p68](https://doi.org/10.5539/mas.v6n1p68).
- [8] Yon, H., Awang, A. H., Ali, M. T., Subahir, S., & Kamaruddin, S. N. (2016, December). Comparative analysis for multilayer stacked substrates microstrip patch antenna. In *2016 IEEE Asia-Pacific Conference on Applied Electromagnetics (APACE)* (pp. 34-37). IEEE.
- [9] Mishra, R., Mishra, R. G., Chaurasia, R. K., & Shrivastava, A. K. (2019). Design and analysis of microstrip patch antenna for wireless communication. *International Journal of Innovative Technology and Exploring Engineering*, 8(7), 663-666.
- [10] Ahmed, R. K., & Ali, I. H. (2017). Sausage Minkowski square patch antenna for GPS application. *International Journal of Advances in Engineering & Technology*, 10(3), 285.
- [11] Almazok, S. A., Mami, A. O., & Aldrewy, S. A. M. (2023). Performance Comparison of 28 GHz Rectangular Patch Antenna Based on Three Different Dielectric Constant Substrates for 5G Communications. *The International Journal of Engineering & Information Technology (IJEIT)*, 11(1), 1-19.
- [12] Srivastava, A., & Pradhan, N. (2017). Analysis of Different Substrate Material & Frequency on Microstrip Patch Antenna. *International Journal of Electronics, Electrical and Computational System*, 6(2), 58-64.
- [13] Colaco, J., & Lohani, R. (2020, June). Design and Implementation of microstrip patch antenna for 5G applications. In *2020 5th International Conference on Communication and Electronics Systems (ICCES)* (pp. 682-685). IEEE.
- [14] W. Ahmad and W. T. Khan, 'Small form factor dual band (28/38 GHz) PIFA antenna for 5G applications', *2017 IEEE MTT-S Int. Conf. Microwaves Intell. Mobility, ICMIM 2017*, no. March, pp. 21–24, 2017, doi: [10.1109/ICMIM.2017.7918846](https://doi.org/10.1109/ICMIM.2017.7918846).
- [15] O. Darboe, J. Kenyatta, F. Manene, D. Konditi, D. Bernard, and O. Konditi, 'A 28 GHz Rectangular Microstrip Patch Antenna for 5G Applications', *Int. J. Eng. Res. Technol.*, vol. 12, no. 6, pp. 854–857, 2019.
- [16] M. Darsono and A. R. Wijaya, 'Design and simulation of a rectangular patch microstrip antenna for the frequency of 28 GHz in 5G technology', *J. Phys. Conf. Ser.*, vol. 1469, no. 1, 2020, doi: [10.1088/1742-6596/1469/1/012107](https://doi.org/10.1088/1742-6596/1469/1/012107).
- [17] Prachi\*, D. V. Gupta, and S. Vijay, 'A Novel Design of Compact 28 GHz Printed Wideband Antenna for 5G Applications', *Int. J. Innov. Technol. Explor. Eng.*, vol. 9, no. 3, pp. 3696–3700, 2020, doi: [10.35940/ijitee.c9011.019320](https://doi.org/10.35940/ijitee.c9011.019320).
- [18] R. Przesmycki, M. Bugaj, and L. Nowosielski, 'Broadband Microstrip Antenna for 5G Wireless Systems Operating at 28 GHz', 2021.
- [19] Rana, M. S., Ovi, S. Z. H., Islam, A. T. U., Mistry, P., Shipon, S. I., Rahaman, M. J., ... & Faruq, O. (2024). For wireless applications, design and analysis of patch antenna at 2.45 GHz. *TELKOMNIKA (Telecommunication Computing Electronics and Control)*, 22(4), 799-811.
- [20] Fante, K. A., & Gameda, M. T. (2020). Broadband microstrip patch antenna at 28 GHz for 5G wireless applications. *International Journal of Electrical and Computer Engineering*, 11(3), 2238-2244.